

**PUMP, VALVE AND DAM
EQUIPMENT
BUTTERFLY VALVES**

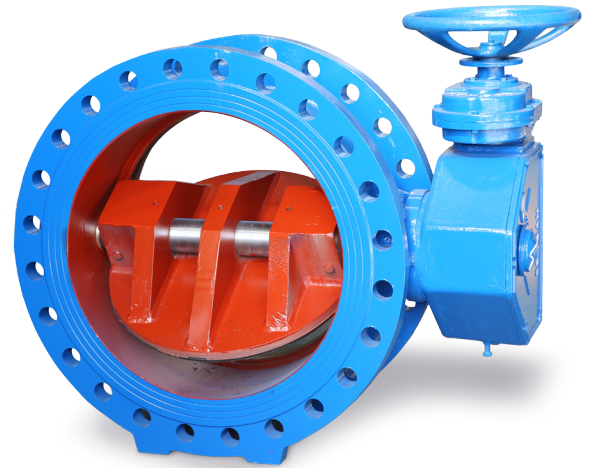

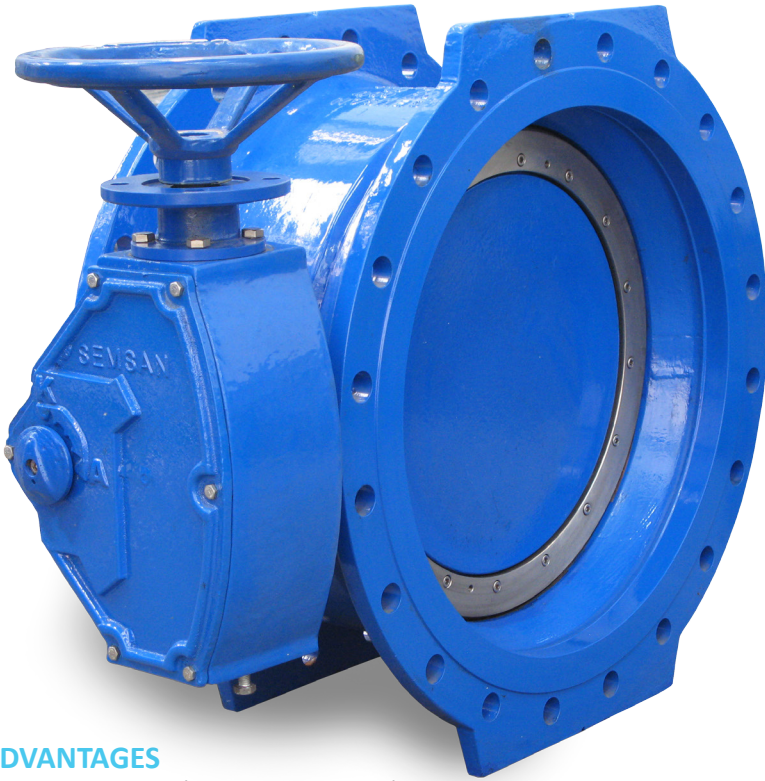

ADVANTAGES

- Compact Design (EN 558-1 Series 14)
- Low Operation Torque for Bigger Diameters with Double Eccentric
- Low maintenance cost
- Leakage Tests, EN 12266 Class A (completely tightness)

DESIGN

- TS EN 593 Certificated
- Double Flange
- Double Eccentric
- Flanges DIN EN 1092 PN 10 – PN40
- Valve Shaft Double Offset
- Face to Face EN 558-1 Series 14 (DIN 3202, F4) (Short Pattern is Optional)
- Mechanical Position Indicator and Limit stops on Gear Box
- Body Sealing Surface;
- Corrosion - Resistant Stainless Welded AISI 316 and Microfinished.
- Adjustable and Replaceable Sealing Ring
- EN 12516 – 1 Steel Welded Design (Optional)
- Max Operation Temperature 50 °C (120 °C Optional)

APPLICATION AREAS

- Drinking Water Lines
- Drinking Water Treatment Plants
- Waste Water Treatment Plants
- Pumping Stations
- Irrigation Projects
- Dams and Reservoirs
- Neutral Gas and Cool Power Plants
- Hydroelectric Power Plants
- Industrial Plants

OPERATION

- Handwheel
- Electrical Actuator
- Pneumatic Actuator
- Hydraulic Actuator
- On – Off or Modulating Operation

CORROSION PROTECTION

- Electrostatic Powder Coating for Drinking Water
- Zinch – Rich Epoxy Primer
- Coal – Tar Epoxy
- Glass Flake Epoxy
- Enamel Epoxy for Ultraviolet
- Completely Stainless Steel Design
- Ebonite Coating for Seawater

LAST QUALITY CONTROL EN 12266 – 1 CLASS A

Nominal Diameter (DN)	Nominal Pressure PN kg / cm2	Test Pressure		Max Pressure for Temperature 50 °C
		Body	Disk	
100.....2800	10	15	11	10
100.....2800	16	24	18	16
100.....2800	25	37,5	27,5	25
100.....2800	40	60	44	40

* All of dimensions and explanations has been given for information. SEMSAN reserve right to keep change all them off.

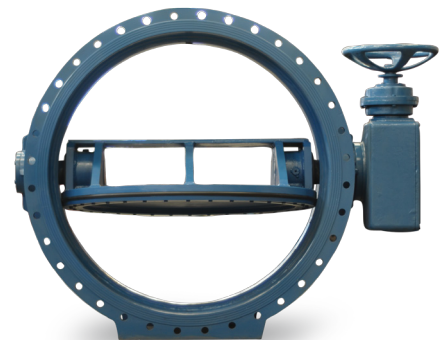

PART LIST

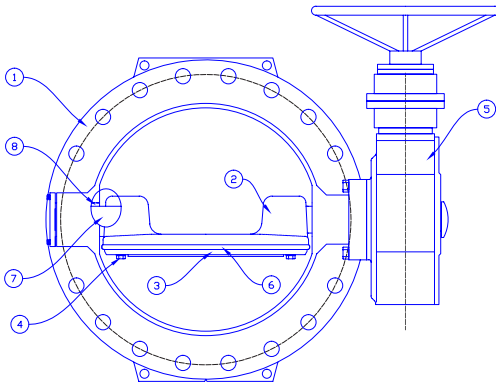

No	Part Name	Material		
1	Body	GGG 40 / 50	ST 37 / ST 52	Stainless Steel
2	Disc	GGG 40 / 50	ST 37 / ST 52	Stainless Steel
3	Sealing Ring Flange	GGG 40 / 50	ST 37 / ST 52	Stainless Steel
4	Bolts and Nuts	A2 Stainless Steel		
5	Gear Box	GGG 40		
6	Sealing Ring	EPDM		
7	Valve Shaft	AISI 420 (X20Cr13)		
8	Bearing	Bronze	Delrin	PTFE
9	Body Seat	AISI 316 Stainless Steel Welded		

BUTTERFLY VALVE ASSEMBLY DRAWING

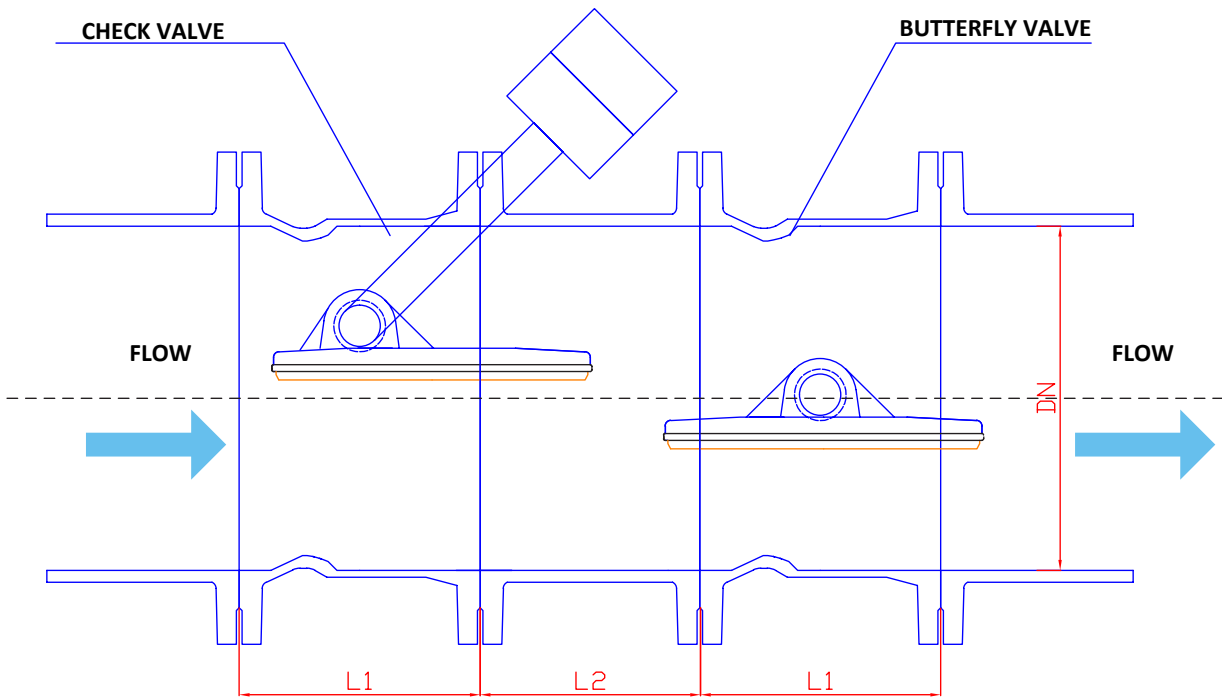

DN	L1 (mm)	L2 (mm)	L3 (mm)
150	210	150	200
200	230	150	220
250	250	150	220
300	270	150	220
350	290	225	230
400	310	225	230
450	330	300	250
500	350	300	260
600	390	400	260
700	430	500	260
800	470	600	290
900	510	650	290
1000	550	750	290
1100	590	800	300
1200	630	900	320
1300	670	1000	340
1400	710	1100	360

EBONITE COATING

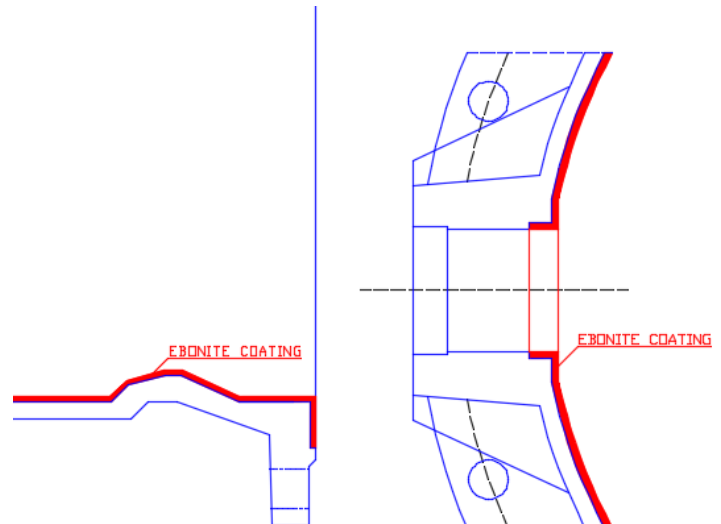

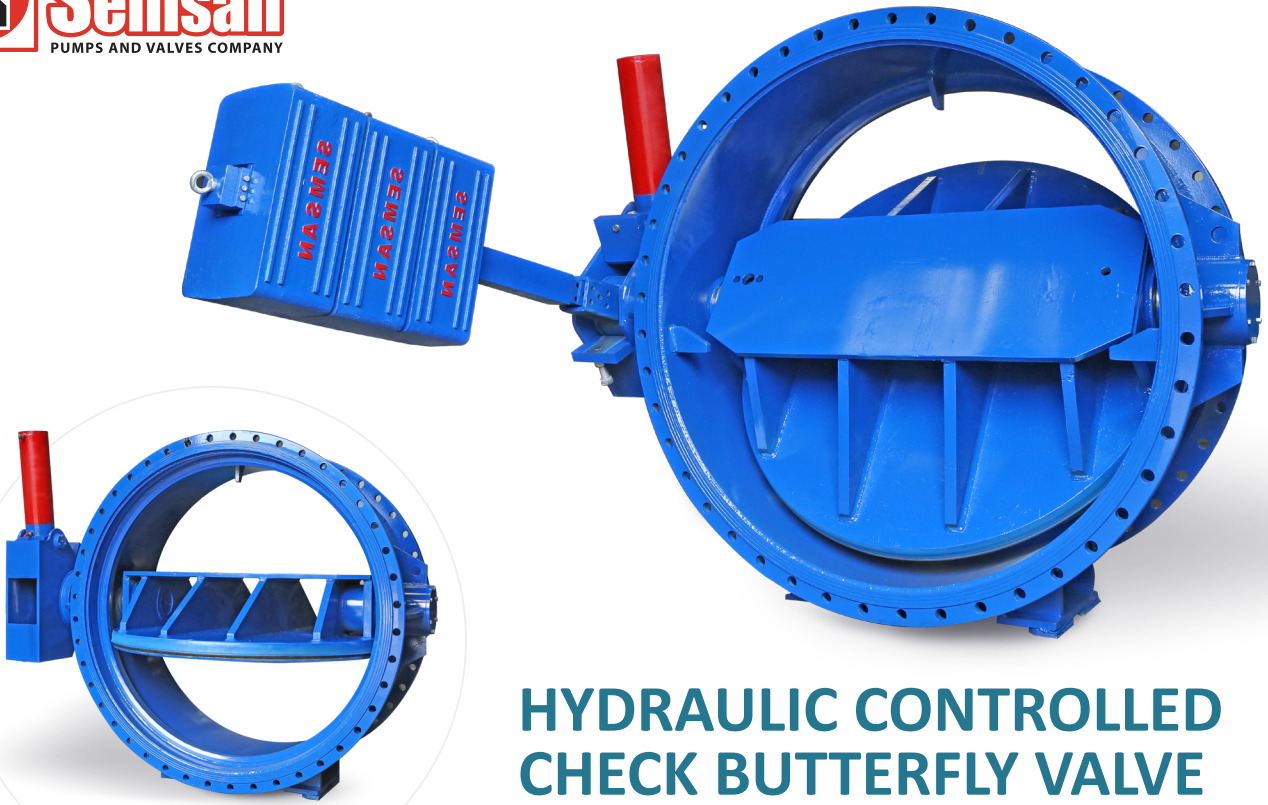

HYDRAULIC CONTROLLED CHECK BUTTERFLY VALVE (TURBINE INLET VALVE)

DN 250/2800 | PN 10 / 16 / 25 / 40

DESIGN

- TS EN 593 Certificated
- Double Flange
- Double Eccentric
- Flanges DIN EN 1092
- Valve Shaft Double Offset
- PN 10 – PN40
- Face to Face EN 558-1 Series 14 (DIN 3202, F4) (Short Pattern is Optional)
- Mechanical Position Indicator and Limit Stops on Gear Box
- Body Sealing Surface; Corrosion - Resistant Stainless Welded AISI 316 and Microfinished.
- Adjustable and Replaceable Sealing Ring
- EN 12516 – 1 Steel Welded Design (Optional)
- Max Operation Temperature 50 °C

APPLICATION AREAS

- Turbine Inlet Valves in Hydroelectric Power Plants
- Emergency Shut Off Valves in Dams and Reservoirs
- Check Butterfly Valves for Pumping Stations

CORROSION PROTECTION

- Electrostatic Powder Coating for Drinking Water
- Zinc – Rich Epoxy Primer
- Coal – Tar Epoxy
- Glass Flake Epoxy
- Enamel Epoxy for Ultraviolet
- Completely Stainless Steel Design
- Ebonite Coating for Seawater

ADVANTAGES

- Opening and Closing With Hydraulic Piston
- Closing With Counter Weight
- High Security Coefficient
- Suddenly Shut-Off for Emergency
- Additional Limit Switch for Hydraulic Leakages
- Two Different Operation Adjust Valve

LAST QUALITY CONTROL EN 12266 – 1 CLASS A

Nominal Diameter (DN)	Nominal Pressure PN kg / cm ²	Test Pressure		Max Pressure for Temperature 50 °C
		Body	Disk	
250.....2800	10	15	11	10
250.....2800	16	24	18	16
250.....2800	25	37,5	27,5	25
250.....2800	40	60	44	40

* All of dimensions and explanations has been given for information. SEMSAN reserve right to keep change all them off.

TURBINE INLET VALVE – EMERGENCY SHUT OFF VALVES

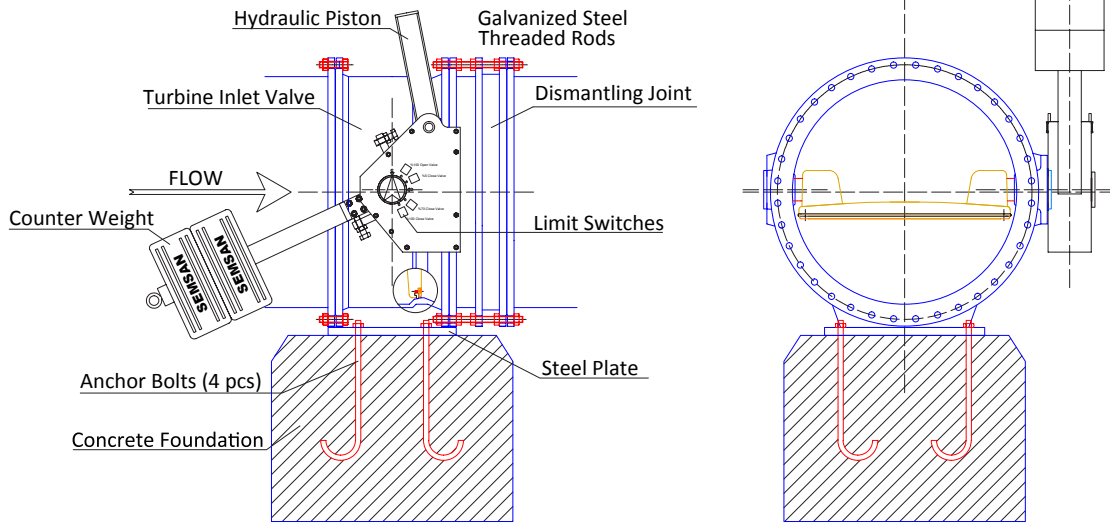

OPERATING PRINCIPLES

Check-Butterfly valve; It is the valve closed by weight fastened to valve shaft and opened by hydraulic pump. Oil pressure disappearing in hydraulic cylinder of the valve opened by hydraulic pump will be supported by accumulator having a diaphragm in the volume of 2,0 L, since S1 and S2 solenoid valves are closed. If cylinder pressure falls down from adjusted pressure, hydraulic pump will operate and increase system pressure. If adjustable pressure shifter doesn't operate, valve will start to close. When it is closed at the rate of 5 %, limit switch on the valve box cover will be closed, pump will operate, increase the system pressure and valve will come into the position of full open.

If close order comes to the valve because of extreme speed and low pressure, it sends 24 V current to the coil of S1 solenoid valve on hydraulic power unit. by opening of S1 solenoid valve, valve starts to close, it completes with high speed the closing ratio of 70 % and with low speed the remaining closing ratio of 30 %.

Valve closing at the ratio of 70 % closes limit switch on the valve box cover, sends 24 V DC current to the coil of S2 solenoid valve on the power unit. Solenoid valve operates and slowly closes 30 % of valve. There are 4 pieces limit switch on the valve box cover

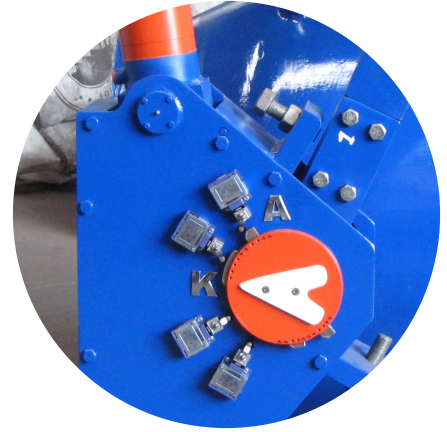

DOUBLE ECCENTRIC DOUBLE FLANGED BUTTERFLY VALVE

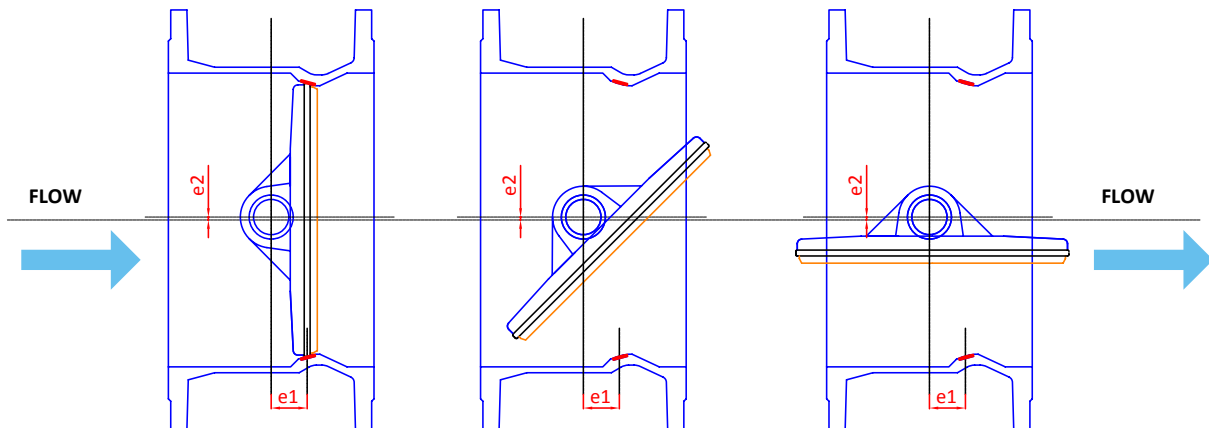

e1: Difference of Sealing Ring Seat Axis – Shaft Axis (For perfect contact of sealing ring to seat surface at flow direction)
 e2: Difference of Disc Axis – Valve Axis (For low operation torque at opening direction)

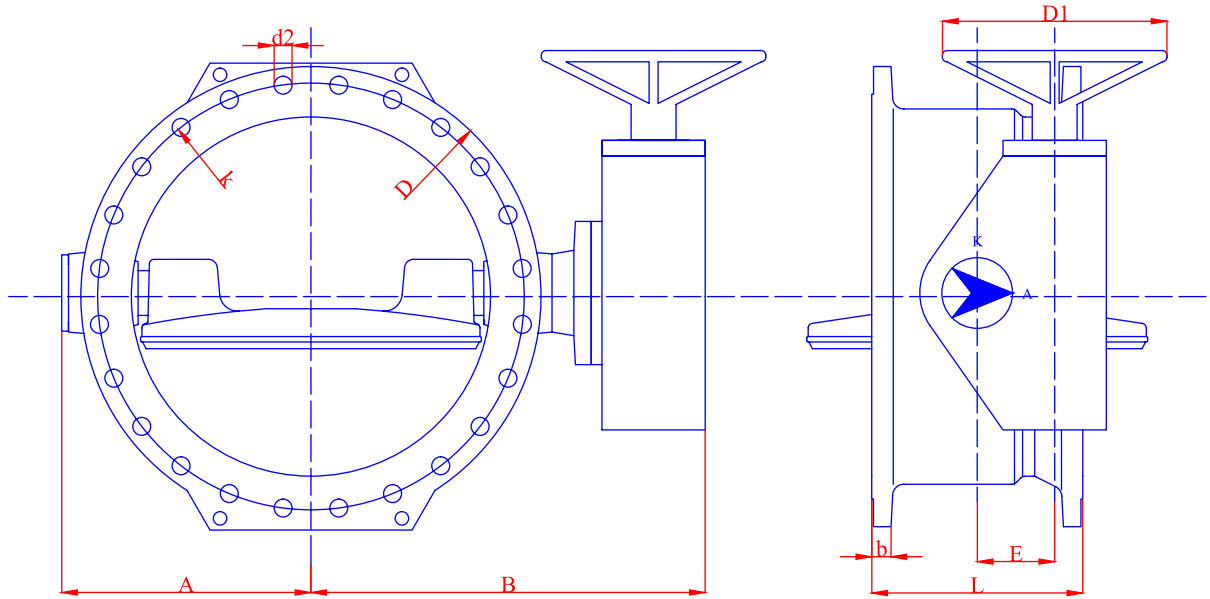

PN10 (DN)	BODY			FLANGES					GEAR BOX			WEIGHT (KG)
	A (mm)	B (mm)	L (mm)	D (mm)	K (mm)	d2 (mm)	b (mm)	No. of Holes	Model	Turn/ Strok	Torque	
150	115	279	210	285	240	23	19	8	DK 60	21	40 Nm	30
200	150	308	230	340	295	23	20	8	DK 60	21	50 Nm	44
250	180	351	250	400	350	23	22	12	DK 85	31	50 Nm	60
300	215	401	270	455	400	23	24,5	12	DK 85	31	80 Nm	81
350	240	411	290	505	460	23	24,5	16	DK 110	23	85 Nm	110
400	261	465	310	565	515	28	24,5	16	DK 110	23	90 Nm	155
450	306	508	330	615	565	28	24,5	20	DK 125	23	90 Nm	190
500	345	339	350	670	620	28	26,5	20	DK 125	23	100 Nm	240
600	392	625	390	780	725	31	30	20	DK 125	23	105 Nm	320
700	462	722	430	895	840	31	32,5	24	DK 160/3	70	95 Nm	470
800	512	772	470	1015	950	34	35	24	DK 160/3	70	100 Nm	620
900	576	880	510	1115	1050	34	37,5	28	DK 160/3	70	105 Nm	800
1000	642	900	550	1230	1160	37	40	28	DK 200/9	225	95 Nm	1050
1100	692	968	590	1340	1270	37	40	32	DK 200/9	225	100 Nm	1390
1200	763	1104	630	1455	1380	40	45	32	DK 200/9	225	105 Nm	1740
1300	830	1235	670	1570	1490	43	45	32	DK 370/9	262	175 Nm	2260
1400	880	1285	710	1675	1590	43	46	36	DK 370/9	262	200 Nm	2545
1500	970	1290	750	1785	1700	43	46	36	PLEASE ASK			
1600	995	1386	790	1915	1820	49	49	40				
1800	1140	1460	870	2115	2020	49	52	44				

* All of dimensions and explanations has been given for information. SEMSAN reserve right to keep change all them off.

PN16	BODY			FLANGES					GEAR BOX			WEIGHT (KG)
	(DN)	A (mm)	B (mm)	L (mm)	D (mm)	K (mm)	d2 (mm)	b (mm)	No. of Holes	Model	Turn/ Strok	
150	115	279	210	285	240	23	19	8	DK 60	21	PLEASE ASK	30
200	150	308	230	340	295	23	20	12	DK 60	21		44
250	180	351	250	400	355	28	22	12	DK 85	31		60
300	215	401	370	455	410	28	24,5	12	DK 85	31		85
350	240	440	290	520	470	28	26,5	16	DK 110	23		116
400	275	463	310	580	525	31	28	16	DK 125	23		115
450	306	508	330	640	585	31	28	20	DK 125	23		237
500	357	583	350	715	650	34	31,5	20	DK 125	23		300
600	413	673	390	840	770	37	36	20	DK 160/3	69		460
700	470	736	430	910	840	37	39,5	24	DK 160/9	207		670
800	537	822	470	1025	950	40	43	24	DK 200/3	75		775
900	615	935	510	1125	1050	40	46,5	28	DK 200/3	75		970
1000	666	985	550	1255	1170	43	50	28	DK 200/9	225		1320
1200	784	1154	630	1485	1390	49	57	32	DK 370/9	262		2090
1400	915	1235	710	1685	1590	49	60	36	DK 370/9	262		2945
1500	1000	1315	750	1820	1710	56	60	36	PLEASE ASK			
1600	1045	1415	790	1930	1820	56	65	40				
1800	1170	1725	870	2130	2020	56	70	44				

PN25	BODY			FLANGES					GEAR BOX			WEIGHT (KG)	
	(DN)	A (mm)	B (mm)	L (mm)	D (mm)	K (mm)	d2 (mm)	b (mm)	No. of Holes	Model	Turn/ Strok		Torque
150	115	277	210	300	250	28	20	8	DK 85	31	PLEASE ASK	32	
200	150	308	230	360	310	28	22	12	DK 85	31		50	
250	180	351	250	425	370	31	24,5	12	DK 110	23		67	
300	215	419	270	485	430	31	27,5	16	DK 110	23		103	
350	240	450	290	555	490	34	30	16	DK 125	23		133	
400	275	485	310	620	550	37	32	16	DK 160	23		174	
450	312	555	330	670	600	37	34,5	20	DK 160	23		280	
500	377	636	350	730	660	37	36,5	20	DK 160/3	69		380	
600	425	679	390	845	770	40	42	20	DK 160/9	207		490	
700	490	755	430	960	875	43	46,5	24	DK 200/9	225		760	
800	571	894	470	1085	990	49	51	24	DK 200/9	225		800	
900	612	954	510	1185	1090	49	59,5	28	DK 200/9	225		1250	
1000	681	1051	550	1320	1210	56	60	28	DK 370/9	262		1685	
1200	813	1175	630	1530	1420	56	74	32	PLEASE ASK				
1400	930	1413	710	1755	1640	62	76	36					
1600	1042	1517	790	1975	1860	62	84	40					
1800	1194	1618	870	2195	2070	70	90	44					

* All of dimensions and explanations has been given for information. SEMSAN reserve right to keep change all them off.

CONTROL TYPES - HYDRAULIC / PNEUMATIC / ELECTRICAL / HANDWHEEL

BUTTERFLY VALVE OPERATION TYPES



HYDRAULIC

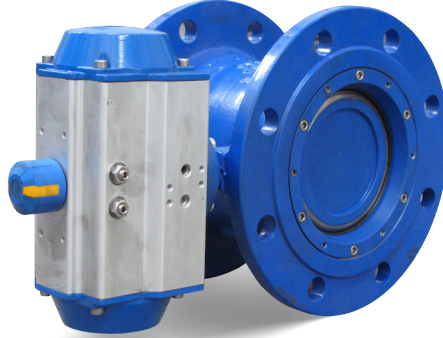

PNEUMATIC

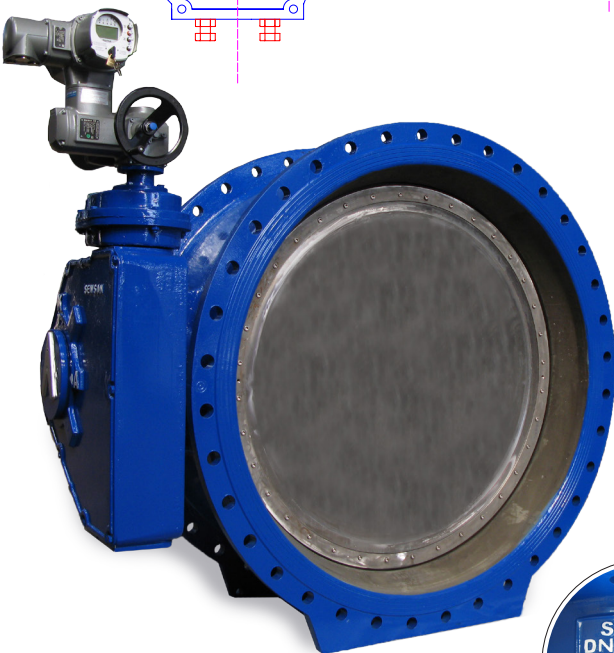
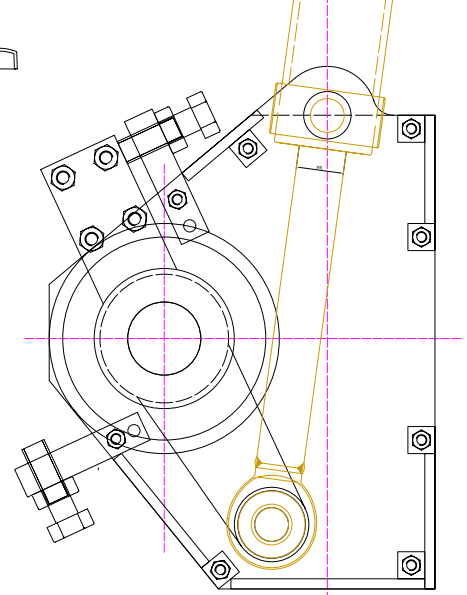
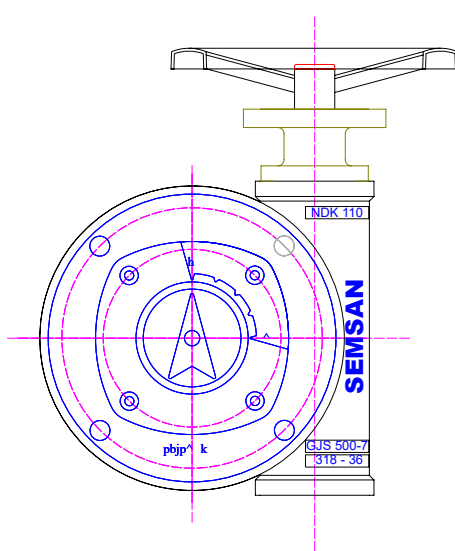
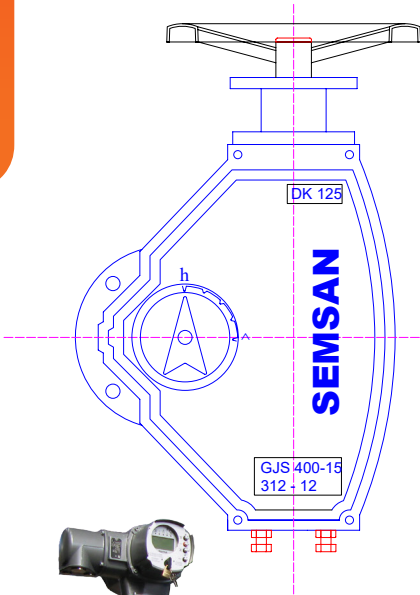

ELECTRICAL



HANDWHEEL



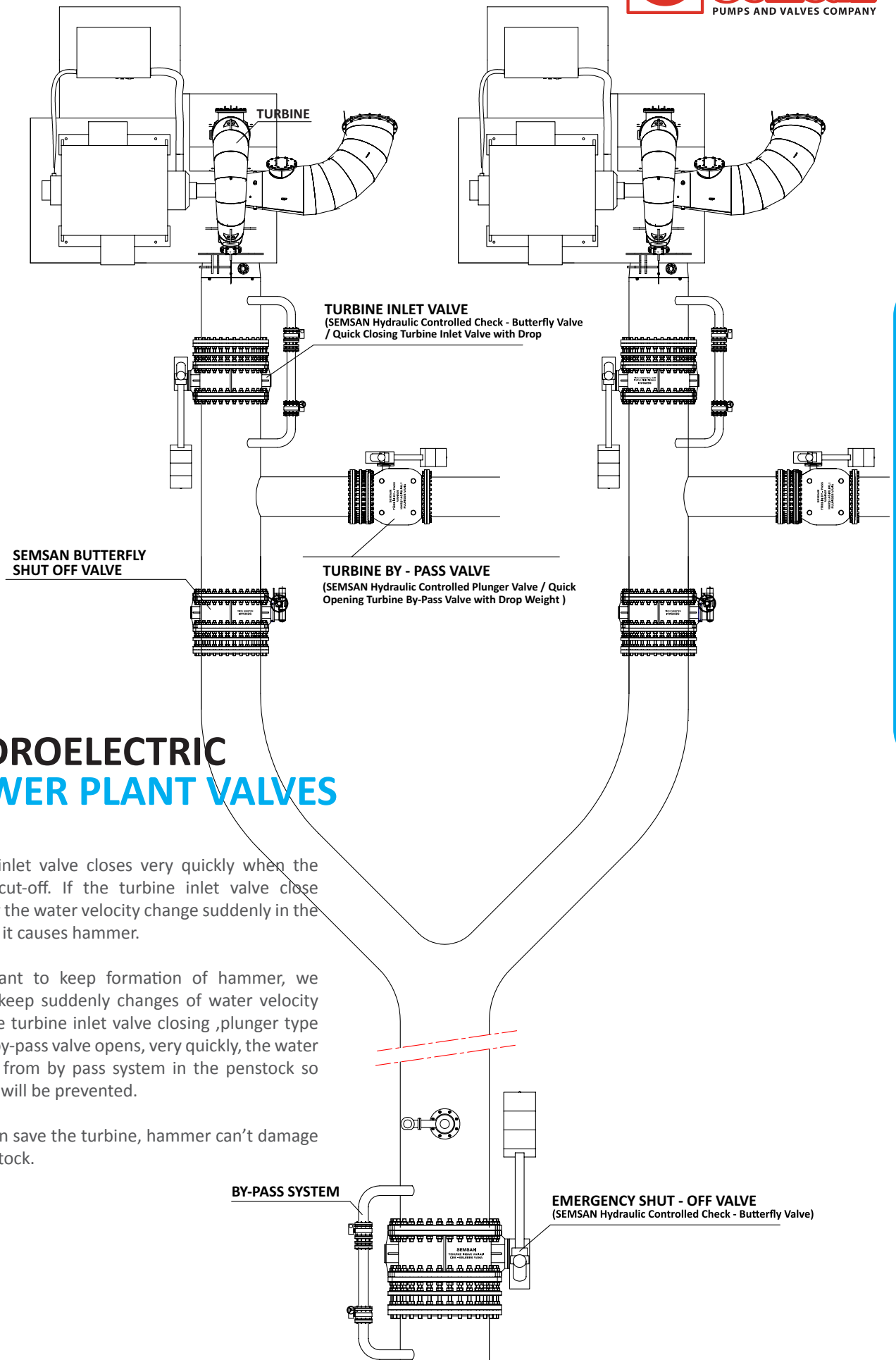

HYDROELECTRIC POWER PLANT VALVES

Turbine inlet valve closes very quickly when the turbine cut-off. If the turbine inlet valve close suddenly the water velocity change suddenly in the pipe and it causes hammer.

If we want to keep formation of hammer, we have to keep suddenly changes of water velocity when the turbine inlet valve closing ,plunger type turbine by-pass valve opens, very quickly, the water released from by pass system in the penstock so hammer will be prevented.

So we can save the turbine, hammer can't damage the penstock.



PUMP, VALVE & DAM
EQUIPMENTS
PRODUCT CATALOGUE

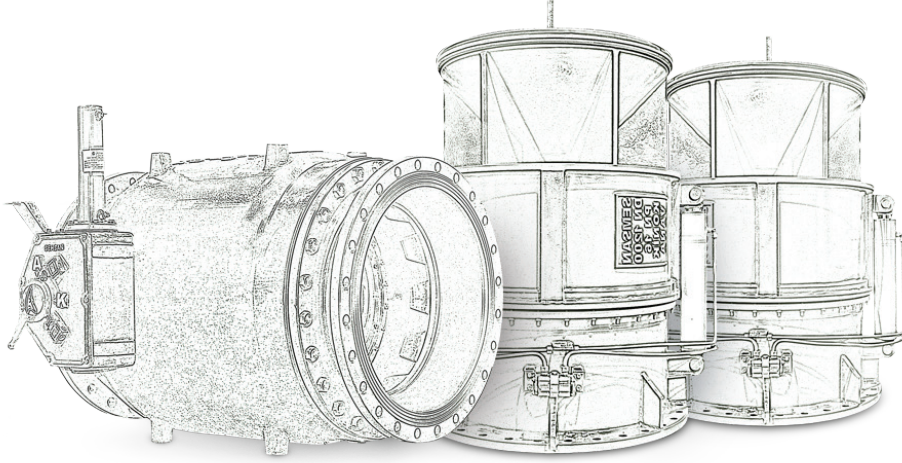

SEMSAN POMPA MAKİNA SANAYİ VE TİCARET LTD. ŞTİ.

Adres : Organize Sanayi Bölgesi Erdoğan Cebeci Bulvarı.
No:42/B Kutlukent / SAMSUN / TURKEY
Phone : +90 362 266 88 33
Fax : +90 362 266 88 58
E-mail : semsan@semsan.com.tr
Web : www.semsan.com.tr

